





## Horizontal thru cable to horizontal steel surface joint - CS9

<b>A</b>				
10	A	#025	HCCP75	MACS910
16	A	#025	HCCP75	MACS916
25	A	#032	HCCP75	MACS925
35	A	#045	HCCP75	MACS935
50	B	#090	HCCP75	MBCS950
70	D	#115	HCCP75	MDCS970
95	D	#115	HCCP100	MDCS995
120	D	#150	HCCP100	MDCS9120
150	D	#200	HCCP100	MDCS9150
185	D	#250	HCCP100	MDCS9185
240	E	2 x #200	HCCP100	MECS9240
300	E	2 x #250	HCCP100	MECS9300
8 dia	D	#090	HCCP75	MDCS98S
10 dia	D	#115	HCCP75	MDCS910S

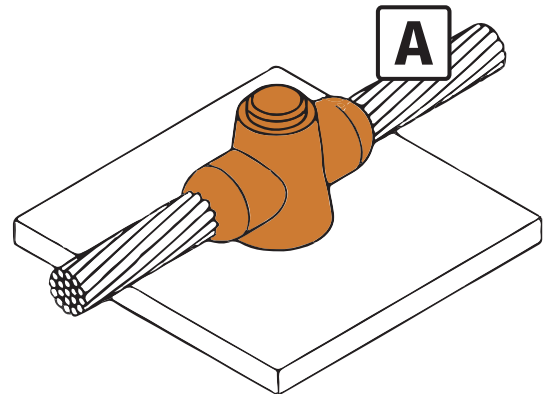

10, 16, 25, 35, 50, 70, 95, 120, 150, 185, 240 and 300  
= stranded cable (mm<sup>2</sup>)

8 dia and 10 dia = solid copper/steel