

PRODUCT DATA SHEET

PART No. PPIT-K-RAL1015

DESCRIPTION: Plastic Earth Pit Kingsmill



KINGSMILL
INDUSTRIES (UK) LTD

SPECIFICATION

PART No.	PPIT-K-RAL1015
DESCRIPTION	Plastic Earth Pit Kingsmill
WEIGHT	3.00Kg (Approx.)
MATERIAL	Polypropylene (body) GRP (lid)
LOAD RATING	6000 kgs
DIMENSIONS	W= 306
	W2= 260
	H= 216
	H1= 55

ADDITIONAL INFORMATION

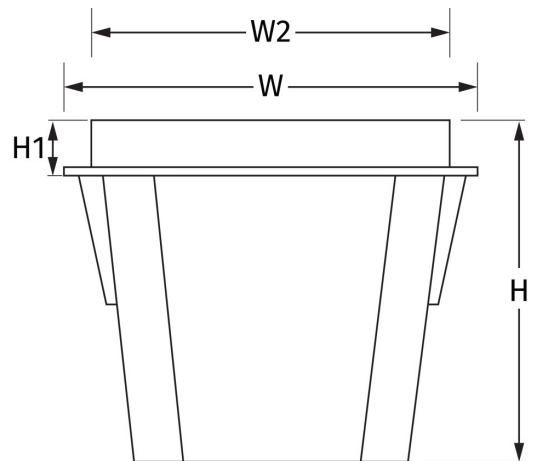

ISOMETRIC VIEW / PRODUCT INFORMATION

AUTHORISATION

Drawn :- M.F	Date:- 06/09/2024
Approved :- M.H	Date:- 06/09/2024
THIS DATA SHEET IS THE PROPERTY OF KINGSMILL INDUSTRIES (UK) LTD	

KINGSMILL
INDUSTRIES (UK) LTD

UNIT 4, PLYMOUTH AVENUE, PINXTON, NG16 6NS, ENGLAND

TEL: +44 (0) 1773 510001 FAX: +44 (0) 1773 863336

E-MAIL: sales@kingsmillearththing.co.uk WEB: www.kingsmillearththing.co.uk