

# PRODUCT DATA SHEET

PART No. MWTC70

DESCRIPTION: Metalwork to Cable Bond

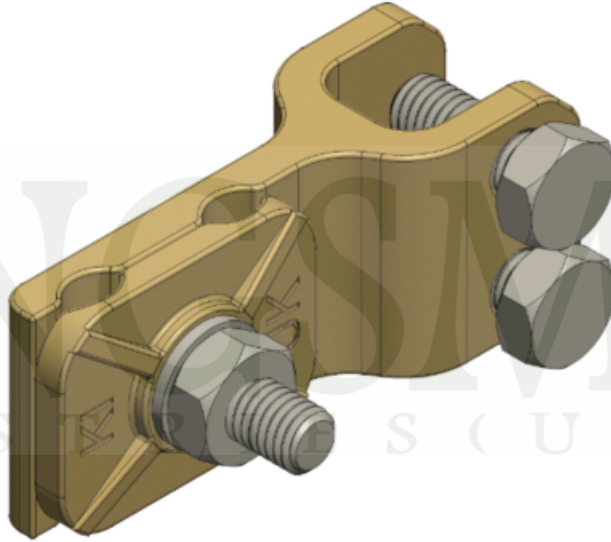

## SPECIFICATION

PART No.	MWTC70
DESCRIPTION	Metalwork to Cable Bond
WEIGHT	0.23 kg (APPROX.)
MATERIAL	Body - C87800 Copper Alloy Fittings - SS304
CONDUCTOR SIZE RANGE	20-70mm <sup>2</sup>
METAL THICKNESS	Up to 15mm
STANDARDS	BS EN 62561-1
TIGHTENING TORQUE	M8 - 10Nm

## GENERAL ARRANGEMENT

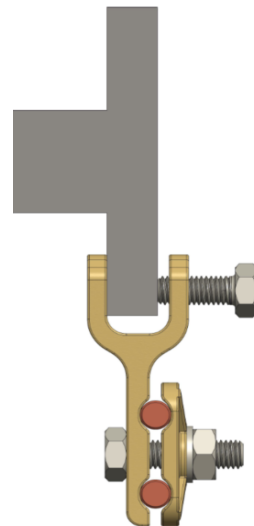

ISOMETRIC VIEW / PRODUCT INFORMATION

## AUTHORISATION

Drawn :- M.F	Date:- 27/11/2024
Approved :- M.H	Date:- 27/11/2024

THIS DATA SHEET IS THE PROPERTY OF KINGSMILL INDUSTRIES (UK) LTD

**KINGSMILL**  
INDUSTRIES (UK) LTD

UNIT 4, PLYMOUTH AVENUE, PINXTON, NG16 6NS, ENGLAND

TEL: +44 (0) 1773 510001 FAX: +44 (0) 1773 863336

E-MAIL: sales@kingsmillearthing.co.uk WEB: www.kingsmillearthing.co.uk